



# MASTER LEDspot LV

## MAS LEDspotLV D 8.0-50W 830 MR16 24D

Delivering intense accent beam, MASTER LEDspot LV is an ideal retrofit solution for spot lighting. MASTER LEDspot LV is designed to replace halogen or incandescent spots. It realizes natural colors, enables cozy and comfortable ambience for residential, hospitality and emphasizes the beauty of merchandise in retail. New smaller housing provides perfect fitting with majority of luminaires in a market with a MR16 GU 5.3 holder. It not only employs Philips' patented solution to guarantee the broadest possible compatibility with standard 12V halogen electronic transformers, it also delivers high beam intensity which is equivalent to halogen MR16 spots. The dimming function enables to create the desired atmosphere and it works with broad selection of dimmers. Its high SDCM ensure stricter color consistency, that is maintained over product life. MASTER LEDspot LV delivers huge energy savings and minimizes maintenance cost without any compromise on light quality and lifetime, enabling residential and business owners to achieve a return on their investment within short period time.

### Product data

General Information	
Cap-Base	GU5.3 [ GU5.3]
Nominal Lifetime (Nom)	40000 h
Switching Cycle	50000X
Technical Type	8-50W
Light Technical	
Color Code	830 [ CCT of 3000K]
Beam Angle (Nom)	24°
Light Distribution	Medium beam 24°
Luminous Flux (Nom)	660 lm
Luminous Flux (Rated) (Nom)	660 lm
Luminous Intensity (Nom)	3250 cd

Color Designation	White (WH)
Rated Beam Angle	24°
Correlated Color Temperature (Nom)	3000 K
Luminous Efficacy (rated) (Nom)	78 lm/W
Color Consistency	<6
Color Rendering Index (Nom)	80
LLMF At End Of Nominal Lifetime (Nom)	70 %
Luminous Flux in 90° Cone (Rated)	621 lm
Operating and Electrical	
Input Frequency	50 to 60 Hz
Power (Rated) (Nom)	8 W
Lamp Current (Nom)	900 mA

# MASTER LEDspot LV

Starting Time (Nom)	0.5 s
Warm Up Time to 60% Light (Nom)	instant full light
Power Factor (Nom)	0.7
Voltage (Nom)	12 V

## Temperature

T-Case Maximum (Nom)	105 °C
----------------------	--------

## Controls and Dimming

Dimmable	Yes
----------	-----

## Approval and Application

Energy Efficiency Label (EEL)	A+
Suitable For Accent Lighting	Yes

Energy Consumption kWh/1000 h	9 kWh
-------------------------------	-------

## Product Data

Full product code	871869649001300
Order product name	MAS LEDspotLV D 8.0-50W 830 MR16 24D
EAN/UPC - Product	8718696490013
Order code	929001149902
Numerator - Quantity Per Pack	1
Numerator - Packs per outer box	10
Material Nr. (12NC)	929001149902
Net Weight (Piece)	0.045 kg

## Dimensional drawing

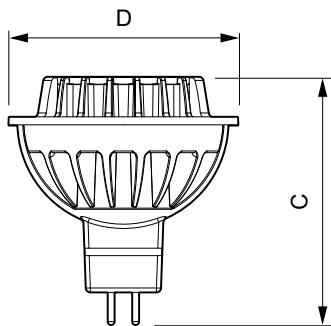

LED D 8-50W 830 MR16 24D

Product	D	C
MAS LEDspotLV D 8.0-50W 830 MR16 24D	51 mm	55 mm

## Photometric data

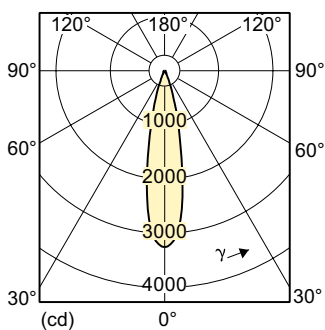

8-50 W GU5.3 /830 MR16 24D

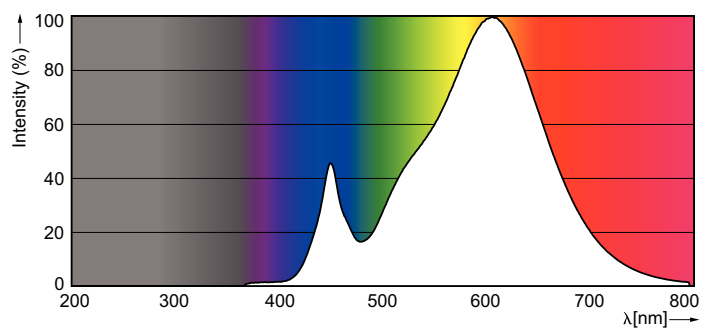

8-50 W GU5.3 /830 MR16

## MASTER LEDspot LV

