

HSAА-1P

- Surge arresters type T3 intended for use in installation and floor boxes and cable trays.
- Additional protection of socket circuits, which are treated with surge protection and high-frequency filters (HSAF, HSAF3).
- Can be used to protect LED lights.
- Installed at the boundaries of LPZ 2 - LPZ 3, as close as possible to the protected device (no further than 5 m).
- In front of HSAА-1P must be installed a lightning current and surge arrester T1 and T2 from HAKEL company.

| Type | | HSAА-1P |
|---|-------------|--|
| Test class according to EN 61643-11:2012 (IEC 61643-11:2011) | | T3 |
| Number of poles | | 2 |
| Rated operating AC voltage | U_N | 230 V |
| Maximum continuous operating voltage AC | U_C | 275 V |
| Nominal discharge current for class II test (8/20) L/N, L/PE | I_n | 3 kA |
| Nominal discharge current for class II test (8/20) N/PE | I_n | 5 kA |
| Open circuit voltage of the combination wave generator (L/N, L/PE) | U_{OC} | 6 kV |
| Open circuit voltage of the combination wave generator (N/PE) | U_{OC} | 10 kV |
| Voltage protection level at U_{OC} (L/N) | U_p | < 1 kV |
| Voltage protection level at U_{OC} (L/PE, N/PE) | U_p | < 1.3 kV |
| Temporary overvoltage test value (TOV) for $t_T = 5$ s (L/N) | U_T | 337 V |
| Temporary overvoltage test value (TOV) for $t_T = 0,2$ s (N/PE) | U_T | 1 200 V |
| Response time (L/N) | t_A | < 25 ns |
| Response time (L/PE, N/PE) | t_A | < 100 ns |
| Maximal back-up fuse | | 16 A gL/gG |
| Lightning protection zone | | LPZ2, LPZ3 |
| Housing material | | Polyamid PA6, UL94 V-0 |
| Degree of protection | | IP20 |
| Operating temperature | ϑ | -40 ÷ 70 °C |
| Installation | | For window sill gutter 45 x 45 mm, In the installation box |
| Operating position | | Any |
| Signalling at the device | | Acoustic |
| Importance of local signaling | | OK – no piezo siren FAULT – piezo siren sound |
| Remote signalling | | No |
| Includes EMI / EMC filter | | No |
| Modular design | | No |
| Lifetime | | > 100 000 h |
| Designed according to standards | | |
| Requirements and test methods for SPDs connected to low-voltage power systems | | IEC 61643-11:2011 |
| Safety of Flammability of Plastic Materials | | UL 94 |

Application standards

| | | |
|--|--|---------------------|
| Protection against lightning | | IEC 62305:2010 |
| Selection and erection of electrical equipment – Devices for protection against transient overvoltages | | HD 60364-5-534:2016 |
| Selection and application principles for SPDs connected to low-voltage power systems | | IEC 61643-12:2008 |

Ordering, packaging and additional data

| | | |
|----------------------------------|---|----------------------|
| Mass | m | 16 g |
| Mass (including the packaging) | m | 27 g |
| Packaging dimensions (H x W x D) | | 98 x 26 x 73 mm |
| Packaging value | V | 0.19 dm ³ |
| ETIM group | | EG000021 |
| ETIM class | | EC000942 |
| Customs tariff no. | | 85363010 |
| EAN code | | |



| | | |
|--------------------|--|---------------|
| Art. number | | 32 007 |
|--------------------|--|---------------|

Internal diagram

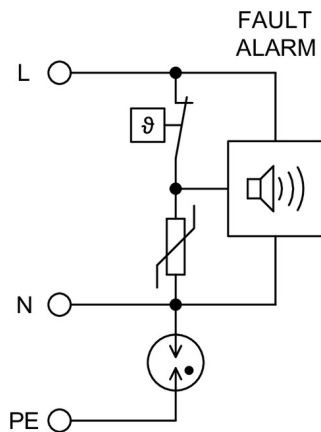

Application wiring diagram (installation)

